



## Experiment 2

### Basic Logic Gates Implementation Using Breadboards and Discrete Gates

#### Introduction:

Logic functions can be implemented in several ways. In the past, vacuum tube and relay circuits performed logic functions. Presently logic functions are performed by tiny integrated circuits (ICs). These ICs are small silicon semiconductor sheets called chips, containing the electronic components for the logic gates. The chip is mounted in a plastic container, and connections are welded to external pins may range from 14 in a small IC package to 64 or more in a large one.

#### Objectives:

- Understand how to use the breadboard to patch up, test your logic design and debug it.
- Wire and operate logic gates such as AND, OR, NOT, NAND, NOR, XOR.
- Understand how to implement simple circuits based on a schematic diagram using logic gates.

#### Theoretical Background:

##### Types of integrated circuits (ICs)

The different sizes of integration of IC chips are usually defined in terms of the number of logic gates in a single IC or package. They are classified in one of the following categories:

1. Small-scale integration (SSI) device: contains less than 10 gates in a single package, such as logic gates.
2. Medium scale integration (MSI) device: contains 10 -100 gates in a single package, such as adders and decoders.
3. Large-scale integration (LSI) device: contains 100 to 10000 gates in a single package, such as processors.
4. Very large-scale integration (VLSI) device: contains more than 10000 gates in a single package, such as complex microprocessors chips.

##### Logic Families

The types of logic devices are classified in "families", of which the most important are TTL and CMOS. The main families are:

- TTL (Transistor-Transistor Logic) made of bipolar transistors.
- CMOS (Complementary Metal Oxide Semiconductor) made from MOSFETs
- ECL (Emitter Coupled Logic) for extremely high speeds
- NMOS, PMOS for VLSI large scale integrated circuits.

##### Subfamilies of TTL Family

There are subfamilies or series of the TTL. Commercial TTL ICs has a number designation that starts with 74 and follows with a suffix that identifies the series type. These subfamilies are:

Standard: 74xx, High speed 74hxx, low power 74Lxx, Shottky TTL 74Sxx, Low power shottky 74LSxx, Advanced shottky 74ASxx, Advanced low-power shottky 74ALSxx.

All TTL IC's are designed to operate from 5V power supply. The input and output logic levels are illustrated in the Figure 1.

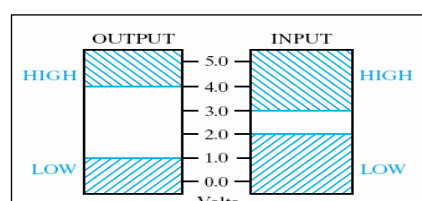

Figure 1

## Some characteristics of the TTL family

1. Power dissipation: It is the amount of power needed by the gate delivered from the power supply. It is equal to 20 mw per gate. Power dissipation is useful to estimate the total power consumption of a system, as an example it will help in portable equipment to know what type of battery might be needed.
2. Fan-in: it is the number of inputs that the gate is designed to have, the maximum inputs is 8 inputs per gate.
3. Fan-out: it is the maximum number of inputs that can be connected to the output of the gate without affecting its normal operation. It is 12 gates.
4. Propagation/time delay: it is the amount of delay between applying the input and the response of the output of the gate. Generally, the propagation delay is in the range of 0.5 to 50 nanoseconds. The total propagation delay time of a logic system will be the delay gate multiplied by the number of gates in series. It is 10 ns per gate.

## Practical TTL Logic Gates

A popular type of IC is illustrated in Figure 2. IC manufacturers refer to this case style as a *dual-in-line package* (DIP). This particular IC is called a 14-pin DIP IC. Just counterclockwise from the notch on the IC is pin 1. A dot (optional) on the top of the IC is another method used to locate pin 1.

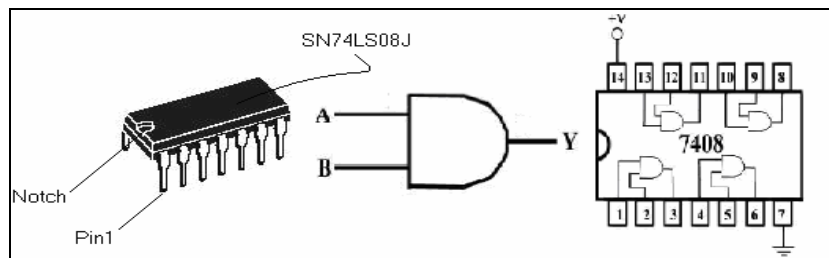

Figure 2

Part Number:

Part number is divided into three sections:

- The prefix: the manufacturer's code.
- Core part number: This determines the technology "TTL or CMOS", the device series and the function of a digital IC.
- The trailing letter(s) "the suffix" which is a code used by several manufacturers to design the DIP.

For example, the part number of:

SN74LS08J

SN: stands for the manufacturer "Texas Instruments"

74: 7400 TTL series

LS: low shottky type

08: function of a digital IC

J: Ceramic dual-in-line Package

## Breadboard

A breadboard is used to build and test circuits quickly before finalizing any circuit design. The breadboard has series of holes into which ICs can be inserted.

- Breadboard Construction:
  - The breadboard has a series of holes, each containing an electrical contact.
  - Holes in the same row (examples highlighted in yellow (1) in Figure3) are electrically connected(they are the same node),holes in other row (highlighted in green (2)) are different node, when you insert a wire into one hole then all the holes in the same node are electrically connected.
  - The gap (highlighted in pink (3)) marks a boundary between the electrical connections. A wire inserted in one of the green holes would not be connected to a wire inserted in one of the yellow holes.
  - The two top rows of holes at the top highlighted in red and blue are used for power supply connections. The first row (highlighted in blue (4)) is connected to ground, all the holes in this row are electrically connected.
  - The second row (highlighted in red (5) ) must connected to 5V , there are 40 holes in this row, each 10 holes are grouped together and electrically connected.
- Using a Breadboard
  1. Before building a circuit, connect 5V from the power supply to V1 (or V2 or V3) in the bread board and 0V the ground of the bread board as shown in the figure below.

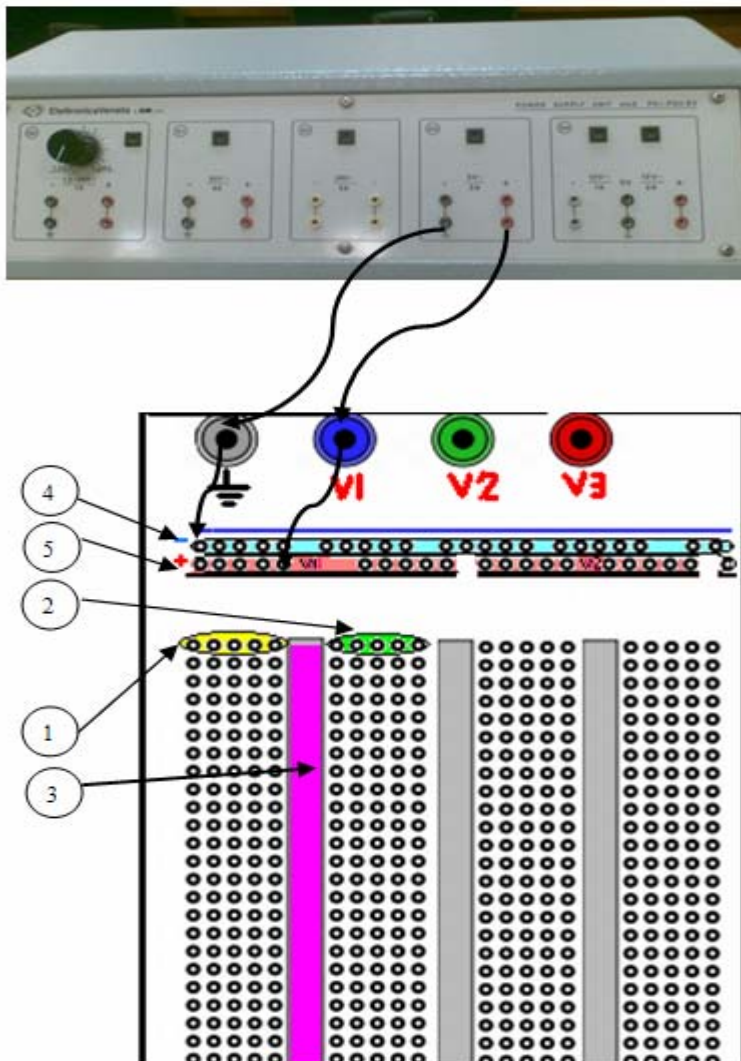

Figure 3

1. Use wires to connect V1 in the bread board to the red terminal(+), and ground of the bread board to the blue terminal(-).
2. Place the IC in the board so that pin 1 should be on the upper left of the board. Half of the legs should be on one side of the pink gap and half on the other.
3. Connect pin 14 of the IC chip to V<sub>cc</sub> and pin 7 to ground.
4. Connect pin 1 and 2 of the IC chip to the input (you can take the input from the two top rows that are connected to the power supply, holes in the first row for logic 0 and holes in the second row for logic 1).

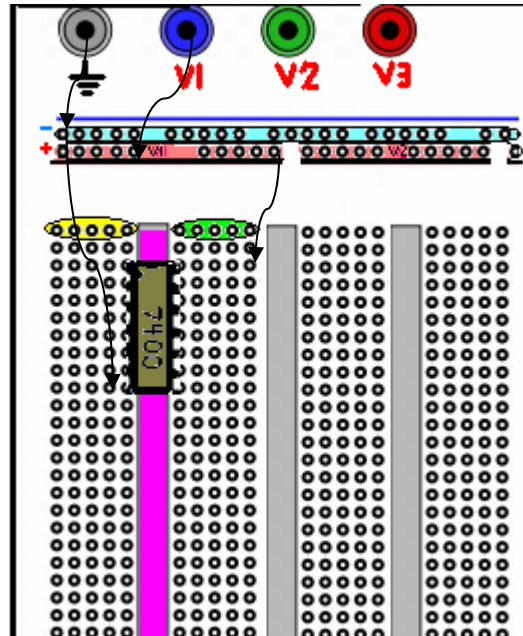

Figure 4

5. You can determine the output using the logic probe, logic probe as shown in (Figure5) is a hand-held pen-like probe used for analyzing and troubleshooting the logical states (Boolean 0 or 1) of a digital circuit. It can be used on either TTL or CMOS integrated circuit devices.
  - a. Attach red alligator clip to positive side of the power supply.
  - b. Attach black alligator clip to a negative side of the power supply.
  - c. Place the tip of the probe on the point you want to test. **Make sure that the switch is in TTL position.**

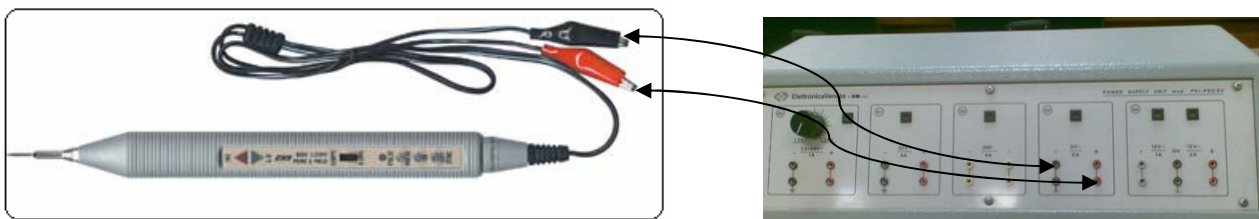

Figure 5

### Wiring Guidelines:

- Arrange the IC chips on the breadboard so that only short wire connections are needed.
- Try to keep the wire as short as possible to avoid a jungle of wires.
- Try to maintain a low wiring profile so that the pins of the chips can be reached and the chip replaced, if necessary. The best connections are those that lie flat on the board.

**Pay extra attention to power and ground. If you find your chips are getting super hot then there is probably a short circuit. Turn off power immediately and wire them correctly.**